

# **AMERICAN SAR 180/275**

**E & L Manufacturing is the SOLE SOURCE and MANUFACTURER  
for new AMERICAN SAR 180 Rifles, Parts and ACCESSORIES**

**Semi-Automatic American 180/275 \$1,250.00**



**TRANSPARENT DRUMS - FIT ALL 180'S**

**NOW YOU CAN VISUALLY CHECK YOUR REMAINING ROUNDS**

**165 / 220 / 275 ROUND DRUMS**

**MAGAZINE AUTO LOADER, LOADING STAND & CARRYING CASE**

## **ORIGINAL AMERICAN 180 • PARTS and SERVICE**

- BARRELS • RECEIVER TOP STRAPS • BOLTS • TRIGGER ASSEMBLIES •
- FEED BLOCKS • SPRINGS • PINS • SEARS • DRUM MAGAZINES •
- WINDERS • WALNUT STOCKS • RETRACTABLE WIRE STOCKS •



**E & L MFG. INC.**

4177 Riddle By-Pass Road • Riddle, OR 97469  
541-874-2137 Fax 541-874-3107



# E & L MANUFACTURING INC.

## Home of the American 180 & The Best Brass Catchers In The World

180 WEB SITE: [www.american180.com](http://www.american180.com) E&L WEB SITE: [www.elmfg.com](http://www.elmfg.com)

E-Mail: [elmfg@frontiernet.net](mailto:elmfg@frontiernet.net)

Phone 541-874-2137 [www.brasscatchers.com](http://www.brasscatchers.com) Fax 541-874-3107

Thank you for your interest in the American 180. Due to the numerous changes in the design throughout the history of the American 180, such as bolts, barrels, receiver design as well as changes in springs, sears, pins, etc., we are unable to supply parts without first knowing the manufacturer/importer as well as model number if known. It is recommended that you call E & L Mfg., Inc. to determine which American 180 you have.

The American 180 is a real pleasure to own. Chances of a malfunction will be greatly reduced, by keeping your rifle clean, well lubricated, and using high quality ammunition. If problems occur, E & L offers a complete service department to keep your rifle operating properly. We will completely tune the rifle for \$200.00 plus parts. Contact E & L for shipping instructions.

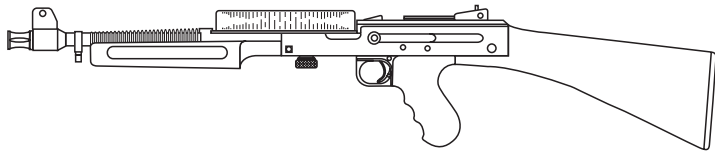

SHIP TO;

NAME \_\_\_\_\_ ADDRESS \_\_\_\_\_

CITY & STATE \_\_\_\_\_ ZIP \_\_\_\_\_

AREA CODE & PHONE \_\_\_\_\_

Specify Manufacturer/ Importer, Make and Model: \_\_\_\_\_

PART #	PART DESCRIPTION	QUANTITY	PRICE EACH	TOTAL

Customer's Notes: \_\_\_\_\_

Subtotal for Merchandise above-----\$ \_\_\_\_\_

**Standard Shipping is Via. U.S. Postal Service Priority Mail**

**Shipping: U.S. & Canada \$ 8.00 for the first \$50.00 from \$51.00 to \$100. add \$2.00**

**Add \$2.00 for each additional \$100.00-----\$ \_\_\_\_\_**

Payment Enclosed

**Foreign Orders Air Mail Shipping: First Item \$12.00**

**Each additional item add \$3.00-----\$ \_\_\_\_\_**

**Total Amount This Order.....\$ \_\_\_\_\_**



Master Card

Visa



American Express



Discover

Card Holder Name \_\_\_\_\_

Card Number \_\_\_\_\_ Exp. Date \_\_\_\_\_ CVV# \_\_\_\_\_

Signature \_\_\_\_\_



# E & L MANUFACTURING INC.

Home of the American 180 & The Best Brass Catchers In The World

180 WEB SITE: [www.american180.com](http://www.american180.com) E&L WEB SITE: [www.elmfg.com](http://www.elmfg.com)

E-Mail: [elmfg@frontiernet.net](mailto:elmfg@frontiernet.net)

Phone 541-874-2137 [www.brasscatchers.com](http://www.brasscatchers.com) Fax 541-874-3107

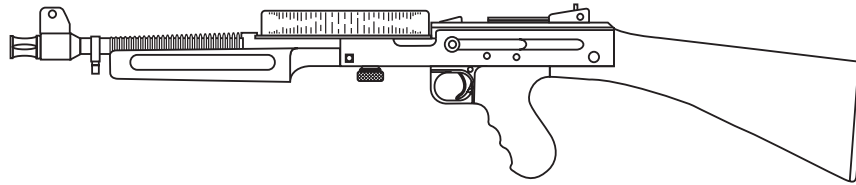

## AMERICAN 180 REPLACEMENT PARTS LIST

INSTRUCTION MANUAL (ILARCO - FEATHER) ..... \$ 10.00

INSTRUCTION MANUAL (AUSTRIAN & AMERICAN ARMS) ..... \$ 10.00

### NOTE:

† CALL FOR AVAILABILITY

### BARREL ASSEMBLY

1001001-000	TALL FRONT SIGHT COMPLETE .....	\$ 5.00
1102003-000-H	BARREL RETAINING KNOB ASSEMBLY (ILARCO-E&L).....	20.00
1102003-000-A	BARREL RETAINING KNOB (AUSTRIAN) .....	12.00
1001007-000	FLASH SUPPRESSOR .....	30.00
1001003-000	SLING RING (BARREL ONLY).....	12.00
1001007-000-A	SLING MOUNTING KIT FRONT & BACK (AUSTRIAN) .....	25.00
1001010-000	16 3/4" STANDARD SEMIAUTO BARREL .....	200.00
	16 3/4" FINNED & THREADED FOR SUPPRESSOR .....	250.00
	9" MACHINE GUN BARREL .....	†250.00
1004006-000	MILITARY FOREGRIP STOCK (BLACK) OUT OF STOCK † -----	
1004007-000	WALNUT FOREARM STOCK .....	25.00
1004007-001	WALNUT PISTOL GRIP FOREARM .....	† 30.00

### TRIGGER GRIP ASSEMBLY

1003000-000	TRIGGER HOUSING WITHOUT GRIP (STRIPPED).....	\$ 80.00
1003002-000	TRIGGER RETURN PLUNGER .....	2.50
1303008-000	TRIGGER, RETURN SPRING .....	.60
1304002-016	TRIGGER PIVOT DOWEL PIN .....	6.00
1301005-064	PAN HEAD SCREW, 1/4-20 X 4.00" .....	3.00
1305000-006	FLAT WASHER, 1/4" .....	1.25
1004003-000	MILITARY TRIGGER GRIP (BLACK) .....	† 20.00
1004008-000	WALNUT TRIGGER GRIP.....	50.00

### SELECT FIRE:

1003001-000	TRIGGER, SELECT FIRE .....	\$ 30.00
1303009-000	SEAR RETURN SPRING .....	3.00
1306003-002	BALL BEARING, .312" DIA .....	2.00
1305000-006	FLAT WASHER, 1/4" .....	1.25
1103000-000	COMPLETE TRIGGER GRIP ASSEMBLY, (MILITARY) .....	†135.00
1103000-001	COMPLETE TRIGGER GRIP ASSEMBLY, (WALNUT) .....	155.00

### SEMIAUTOMATIC:

1003001-001	TRIGGER, SEMI-AUTOMATIC .....	\$ 25.00
1103000-002	COMPLETE TRIGGER GRIP ASSEMBLY, (MILITARY) .....	† 125.00
1103000-003	COMPLETE TRIGGER GRIP ASSEMBLY, (WALNUT) .....	145.00

### SHOULDER STOCK ASSEMBLY

1004000-000	STOCK RELEASE PIN .....	\$ 12.00
1004001-000	STOCK MOUNTING PLATE.....	45.00
1303010-000	STOCK RETAINING SPRING.....	2.50
1301014-020	FLAT HEAD WOOD SCREW, #8 X 1.25" (2) .....	1.50
1301002-006	PAN HEAD SCREW, 8-32 X .375".....	1.00
1305000-004	FLAT WASHER, #8 .....	1.00
1004004-000	MILITARY SHOULDER STOCK <u>OUT OF STOCK</u> .....	† 00.00
1004009-000	WALNUT SHOULDER STOCK .....	125.00
1104000-000	COMPLETE MILITARY STOCK (3 PART SET) <u>OUT OF STOCK</u> .....	
1104000-001	COMPLETE WALNUT STOCK (3 PART SET) .....	185.00
1104000-001-WS	RETRACTABLE WIRE STOCK .....	60.00

### MAGAZINE ASSEMBLY

1106000-165-S	MAGAZINE ASSEMBLY (ALL METAL USED).....	† \$ 275.00
1106000-177-S	MAGAZINE ASSEMBLY (ALL METAL USED).....	† 300.00
1106000-165-L	165 RND CLEAR MAGAZINE ASSEMBLY (LEXAN) .....	† 100.00
1106000-220-L	220 RND CLEAR MAGAZINE ASSEMBLY (LEXAN).....	† 125.00
1106000-275-L	275 RND CLEAR MAGAZINE ASSEMBLY (LEXAN).....	† 150.00
1106004-001	MAGAZINE FOLLOWER (STEEL 165 & 177).....	40.00
1106004-001-L	MAGAZINE FOLLOWER (LEXAN E&L).....	5.00
1006004-000	MAGAZINE BOTTOM PLATE (ALUMINUM)W/HARDWARE.....	45.00
1006004-111	MAGAZINE BOTTOM PLATE (LEXAN E&L) .....	20.00
1006005-000-L	MAGAZINE RETAINING RING (LEXAN).....	5.00
1006007-000	WINDER RETAINING SPRINGS (2 PER SET).....	10.00
1006006-000	SPACER WASHER (2 PER SET) .....	5.00
1301002-004	PAN HEAD SCREW, 8-32 X .250" (4 PER SET) .....	2.00
1305000-004	FLAT WASHER, #8 (2 PER SET).....	2.00
1006012-000	LOADING TOOL.....	5.00
1006012-001-L	LOADING TRAY (TRANSPARENT LEXAN).....	35.00

### BOLT ASSEMBLY

#### SELECT FIRE:

1002011-000	SELECT FIRE BOLT .....	\$ 125.00
1002016-000	M2 EXTRACTOR .....	15.00
1303001-000	EXTRACTOR SPRING .....	1.00
1304004-000	ROLL PIN, .085 DIA X .562" .....	1.00
1002006-000	BOLT SPRING GUIDE.....	8.00
1306001-000	SPRING CLIP, E TYPE.....	.60
1303000-000	BOLT SPRING .....	15.00

#### SEMI-AUTO:

1002026-001-SB	SEMI-AUTOMATIC BOLT (NEW SELF CLEANING).....	\$150.00
1002032-001-E	M1 EXTRACTOR .....	15.00
1303001-000	EXTRACTOR SPRING .....	1.00
1304004-009	ROLL PIN, .085 DIA X .562" (2).....	1.00
1002033-001-FP	FIRING PIN (SEMI-AUTOMATIC).....	25.00
1002031-000	BOLT SPRING GUIDE (SEMI-AUTOMATIC).....	35.00
130314-001-BS	BOLT SPRING (SEMI-AUTOMATIC) .....	15.00
1002030-000	FIXED SEAR.....	20.00
1002029-000	STRIKER RELEASE .....	20.00
1303012-000	STRIKER RELEASE SPRING .....	4.00
1303013-000	STRIKER SPRING.....	15.00
1303014-000	STRIKER ASSEMBLY .....	50.00

### WINDER ASSEMBLY

1107000-001-G	COMPLETE WINDER ASSEMBLY (GEARED).....	\$ 75.00
1107000-001-UG	COMPLETE WINDER ASSEMBLY (UNGEARED) .....	75.00
SHIP YOUR WINDER TO E&L FOR CONVERSION TO NON-GEARED .....		25.00

### SAFETY SHAFT ASSEMBLY

• IMPROVED M-16 STYLE •

1102001-001-SSF	SAFETY SHAFT ASSEMBLY (SELECT FIRE) .....	\$ 25.00
1102008-001-SSS	SAFETY SHAFT ASSEMBLY (SEMI-AUTOMATIC) .....	



# E & L MANUFACTURING INC.

Home of the American 180 & The Best Brass Catchers In The World

180 WEB SITE: [www.american180.com](http://www.american180.com) E&L WEB SITE: [www.elmfg.com](http://www.elmfg.com)

E-Mail: [elmfg@frontiernet.net](mailto:elmfg@frontiernet.net)

Phone 541-874-2137 [www.brasscatchers.com](http://www.brasscatchers.com) Fax 541-874-3107

## TOP STRAP ASSEMBLY

1005000-001-TS	TOP STRAP.....	\$ 125.00
1005001-001-MR	MAGAZINE RETAINER & RELEASE (IMPROVED).....	25.00 SET
1303006-000	MAGAZINE RETAINER SPRING.....	1.00
1304004-009	ROLL PIN, .085 DIA X .562" .....	1.00
1306000-001-RS	REAR SIGHT .....	80.00
1301000-003	PAN HEAD SCREW, 5-40 X .187".....	1.00
1305001-002	SPLIT LOCK WASHER, #5.....	1.00
1105000-001-TSC	TOP STRAP ASSEMBLY (COMPLETE) SAVE \$15.00.....	215.00

## FEED BLOCK ASSEMBLY

1102002-001-FBH	FEED BLOCK ASSEMBLY (HEAVY BARREL) .....	\$ 125.00
1102002-001-FBT	FEED BLOCK ASSEMBLY ("T" SLOTTED BARREL).....	125.00
INSTALL RETAINING SET SCREWS IN YOUR FEED BLOCK.....		50.00

## SEAR ASSEMBLY

1002012-001-S	SEAR .....	\$ 45.00
1002007-001-SP	SELECTOR PIN .....	15.00
1002017-000	SELECTOR DETENT PIN .....	3.00
1303003-000	SELECTOR DETENT PIN SPRING .....	1.50
1301008-004	SET SCREW, 8-36 X .250" .....	1.00
1102004-001-SAC	.....	
SEAR ASSEMBLY KIT WITH SELECTOR (SAVE \$10.50) .....		55.00

## RECEIVER ASSEMBLY

1002008-000	TRIGGER ASSEMBLY STOP PIN SLEEVE.....	\$ 4.00
1002009-000	STOCK RETAINING PIN SLEEVE.....	3.50
1002024-000	TOP STRAP BEARING SLEEVE .....	5.00
1002010-000	TRIGGER ASSEMBLY STOP PIN.....	2.00
1303004-000	TRIGGER ASSEMBLY STOP PIN SPRING .....	1.00
1002013-000	COCKING KNOB BOLT (AUSTRIAN & US).....	25.00
1002004-000	COCKING KNOB.....	15.00
1002015-000	COCKING KNOB DUST COVER .....	15.00
1303002-000	SAFETY DETENT SPRING .....	1.00
1301010-000	SET SCREW, 1/4-28 X .312" .....	1.25
1304000-004	DOWEL PIN, SAFETY STOP, .062 DIA X .250" .....	2.00
1306003-000	BALL BEARING, .078" DIA (SAFETY) .....	1.50
1306003-001	BALL BEARING, .250" DIA (TOP STRAP).....	.75
1304003-004	ROLL PIN, .067 DIA X .250" .....	.50
1102003-001-HBN	BARREL RETAINING KNOB ASSEMBLY (HVY BRL).....	25.00
1102003-001-ABN	BARREL RETAINING KNOB (AUSTRIAN) .....	12.00
1102004-001-SAK	SEAR ASSEMBLY KIT WITH SELECTOR.....	55.00
1304006-000	SOLID PIN, .250" SQUARE.....	12.00
1306005-000	SLING STUD (ILARCO, FEATHER, E&L) .....	7.50
1002008-000	TRIGGER ASSEMBLY STOP PIN SLEEVE.....	6.00
1002009-000	STOCK RETAINING PIN SLEEVE.....	4.00
1002024-000	TOP STRAP BEARING SLEEVE .....	6.00
1002010-000	TRIGGER ASSEMBLY STOP PIN.....	3.00
1303004-000	TRIGGER ASSEMBLY STOP PIN SPRING .....	1.00
1303002-000	SAFETY DETENT SPRING .....	1.00
1301010-000	SET SCREW, 1/4-28 X .312" (REPLACEMENT FOR ABN)	1.25
1304000-004	DOWEL PIN, SAFETY STOP, .062 DIA X .250" .....	2.00
1102008-001-SSF	.....	
SAFETY SHAFT ASSEMBLY, SEMI-AUTO .....		30.00
1102001-001-SSS	.....	
SAFETY SHAFT ASSEMBLY, SELECT FIRE.....		25.00

## RECEIVER ASSEMBLY CONTINUED

1306005-000	SLING MOUNTING KIT FRONT & BACK (AUSTRIAN) .....	25.00
1303014-000	TOP STRAP DETENT SPRING .....	15.00
1002006-000	BOLT SPRING GUIDE, SELECT FIRE.....	8.00
1002031-000	BOLT SPRING GUIDE, SEMI-AUTO .....	35.00
1303000-001-BS	BOLT SPRING, SELECT FIRE .....	15.00
130314-001-BS	BOLT SPRING, SEMI-AUTO .....	15.00
1002029-000	STRIKER RELEASE .....	20.00
1303012-000	STRIKER RELEASE SPRING .....	4.00
1303013-000	STRIKER SPRING.....	20.00
1002030-000	FIXED SEAR, SEMI-AUTO.....	20.00
1002007-001-SP	FIRE SELECTOR PIN .....	15.00

## ACCESSORIES

1401000-001-SC	SOFT CARRYING CASE (BLACK PADDED CORDURA) .....	\$ 60.00
1006012-001-LT	LOADING TRAY (TRANSPARENT LEXAN).....	35.00
1006012-001-MLS	MAGAZINE LOADING STAND .....	25.00
1401000-001-RBR	RECEIVER CLEANING BRUSH & ROD.....	15.00
1401000-001-MB	MAGAZINE CLEANING BRUSH (SPECIAL).....	10.00
1006012-001-WS	RETRACTABLE WIRE STOCK .....	60.00

## WEIGHTS & MEASURES:

Gun — 6 lbs.  
36 3/4" Long Over all  
18" Heavy Barrel  
.22 Long Rifle  
Winder — 1 lb

### Magazine Weights:

165 - Lexam Magazine (Loaded) --- 1 3/4 lds.  
220 - Lexan Magazine (Loaded) --- 2 1/4 lbs.  
275 - Lexan Magazine (Loaded) --- 2 1/2 lbs.  
Compared To:  
177 Metal Mag. (Empty) --- 2 1/4 lbs.  
177 Metal Mag. (Loaded) --- 3 1/2 lbs.



# **E & L MANUFACTURING INC.**

Home of the American 180 & The Best Brass Catchers In The World

180 WEB SITE: [www.american180.com](http://www.american180.com) E&L WEB SITE: [www.elmfg.com](http://www.elmfg.com)

E-Mail: [elmfg@frontiernet.net](mailto:elmfg@frontiernet.net)

Phone 541-874-2137 [www.brasscatchers.com](http://www.brasscatchers.com) Fax 541-874-3107

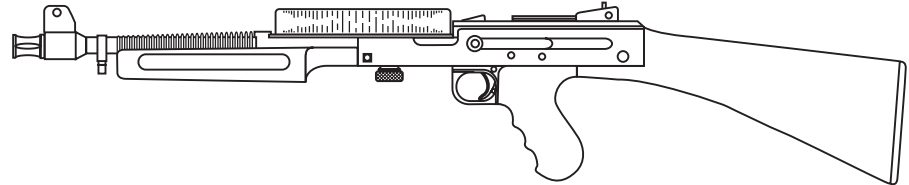

## **AMERICAN 180 LARGE CAPACITY DRUM MAGAZINES**

E & L Manufacturing, Inc. still has available for immediate shipment new pre-ban Lexan magazines in three different sizes for the American 180 .22 Rifle.

The 165 round transparent Lexan drum magazine weighs only 1 lb. 13 oz. loaded compared to 3 lbs. 9 oz. with a loaded 177 round drum. That's 1 lb. 12 oz. less weight! The same advantages, reliability, durability and ease of loading as well as being able to constantly see your remaining rounds are incorporated in all three Lexan magazines.

### **COMPARE THE ADVANTAGES OF REDUCED WEIGHT AND INCREASED FIREPOWER:**

(American 180 Gun only - 6 lbs.. 4 oz.)

Original 177 Round Metal Drum Loaded - 3 lbs. 9 oz. (57 oz.)

E & L Transparent Lexan 220 Round Drum Loaded - 2 lbs. 5 oz. (37 oz.)

**YOU SAVE 1 LB. 4 OZ. IN WEIGHT AND INCREASE FIREPOWER CAPACITY BY 43 ROUNDS!**

E & L Transparent Lexan 275 Round Drum Loaded - 2 lbs. 12 oz. (44 oz.)

**YOU SAVE 13 OZ. IN WEIGHT AND INCREASE FIREPOWER CAPACITY BY 98 ROUNDS!**

**E & L 165 ROUND TRANSPARENT DRUM ..... \$100.00**

**E & L 220 ROUND TRANSPARENT DRUM....\$ 125.00**

**E & L 275 ROUND TRANSPARENT DRUM....\$ 150.00**

We cannot ship High Capacity Magazines to the following; CA, DC, HI, MA, MD, RI and New York City.

CAUTION: Be aware that when the magazine appears to be empty, or spins to indicate it is empty, there may be from one to two rounds still within the receiver and capable of being fired. Always check to see that the gun is empty and pointed in a safe direction.



# **E & L MANUFACTURING INC.**

Home of the American 180 & The Best Brass Catchers In The World

180 WEB SITE: [www.american180.com](http://www.american180.com) E&L WEB SITE: [www.elmfg.com](http://www.elmfg.com)

E-Mail: [elmfg@frontiernet.net](mailto:elmfg@frontiernet.net)

Phone 541-874-2137 [www.brasscatchers.com](http://www.brasscatchers.com) Fax 541-874-3107

## **American 180 Winder Information**

E & L Manufacturing, Inc. has available an Ung geared Winder that will continuously feed the entire contents of all American 180 Magazines including the 220 and the 275 round Lexan drums. The ungeared winder will also work on all metal drums including the original 177 round drum.

**Important:** After installing an Ung geared Winder into the loaded magazine you must wind 2 1/2 turns of pre-wind tension. Then wind an additional 1 full turn per layer of ammunition that has been previously loaded into the magazine.

For example, if you have a completely loaded 177 round metal drum which has three layers of ammunition, you will need to wind the new E & L Ung geared Winder 5 1/2 total turns. This is also true with all 165 round drums.

If you have a completely loaded 220 round Lexan drum, which has four layers so you will need 6 1/2 total turns. A completely loaded 275 round Lexan drum requires 7 1/2 total turns. It is very important not to over wind or under wind.

E & L will re-work your winders for a charge of \$25.00 each plus shipping. The re-worked winder will then function on all drums as described above.

**New Winders: Geared Or Ung geared \$ 75.00**

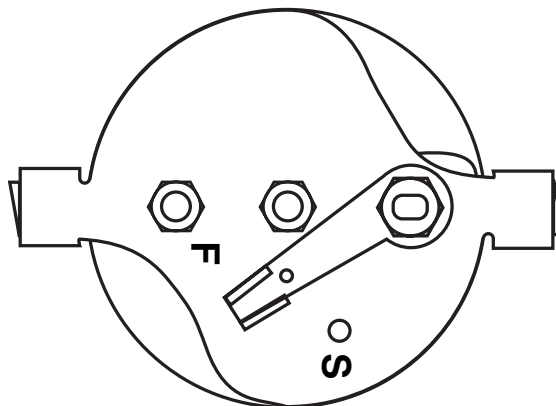



# **E & L MANUFACTURING INC.**

Home of the American 180 & The Best Brass Catchers In The World

180 WEB SITE: [www.american180.com](http://www.american180.com) E&L WEB SITE: [www.elmfg.com](http://www.elmfg.com)

E-Mail: [elmfg@frontiernet.net](mailto:elmfg@frontiernet.net)

Phone 541-874-2137 [www.brasscatchers.com](http://www.brasscatchers.com) Fax 541-874-3107

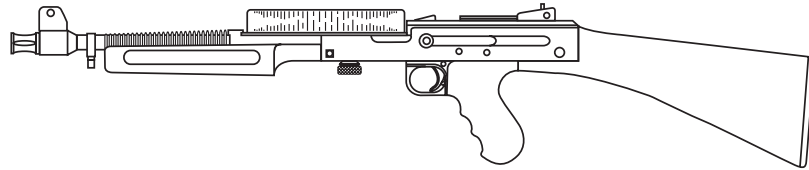

## **AMERICAN 180 LOADING TRAY**

E & L Manufacturing has developed a **LOADING TRAY** that will greatly reduce the time spent loading drum magazines for the American 180.

The complaint most often expressed by American 180 owners is the time consumed in loading drums. With the E & L **LOADING TRAY** attached to the drum magazine, simply empty the contents of a 50 round box of cartridges onto the **LOADING TRAY** and align the cartridges while rotating the drum. The cartridges will feed directly into the drum and the time spent loading will be reduced to approximately 1 minute per layer.

The E & L **LOADING TRAY** will fit all American 180 metal drums as well as the new E & L transparent Lexan drums.

E & L **LOADING TRAY**- \$35.00\_

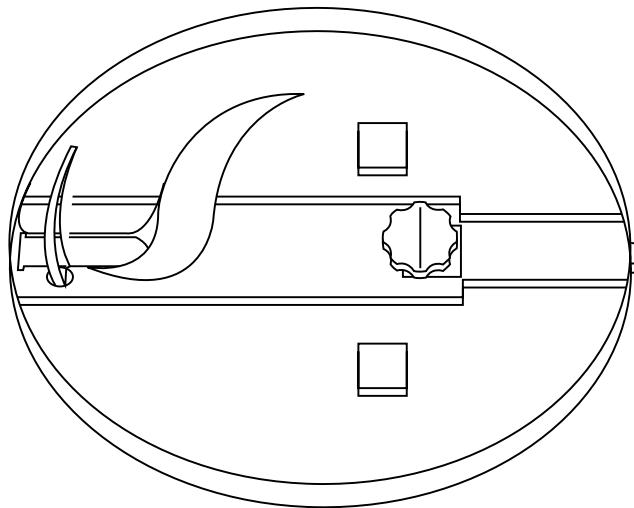

**CAUTION:** Be aware that when the magazine appears to be empty, or spins indicating it is empty, there may be from one to two rounds still within the receiver and capable of being fired. Always check to see that the gun is empty and pointed in a safe direction.





# **E & L MANUFACTURING INC.**

Home of the American 180 & The Best Brass Catchers In The World

180 WEB SITE: [www.american180.com](http://www.american180.com) E&L WEB SITE: [www.elmfg.com](http://www.elmfg.com)

E-Mail: [elmfg@frontiernet.net](mailto:elmfg@frontiernet.net)

Phone 541-874-2137 [www.brasscatchers.com](http://www.brasscatchers.com) Fax 541-874-3107

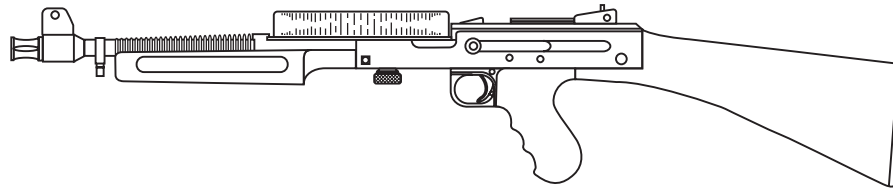

AMERICAN 180 CARRYING CASE

E & L Manufacturing now has available a convenient CARRYING CASE designed especially to accommodate the American 180 with ample room for three large capacity drum magazines including winders and space for the new E & L LOADING TRAY as well as a cleaning rod compartment.

The lined and padded CARRYING CASE is constructed of black Dupont Cordura nylon.

Velcro straps hold the receiver and shoulder stock securely in place on one side, with the barrel and cleaning rod compartments located in the center. The opposite side contains the three large magazine compartments. The center magazine compartment can also be used for other accessories or for storage of extra ammo.

AMERICAN 180 CARRYING CASE - \$60.00

Folds in half and is zippered closed to a compact 12 X 27 inches and only 3 inches thick.

Note: With 3 each 275 round magazines, you could carry 825 rounds along with your gun, loaded and ready to use.

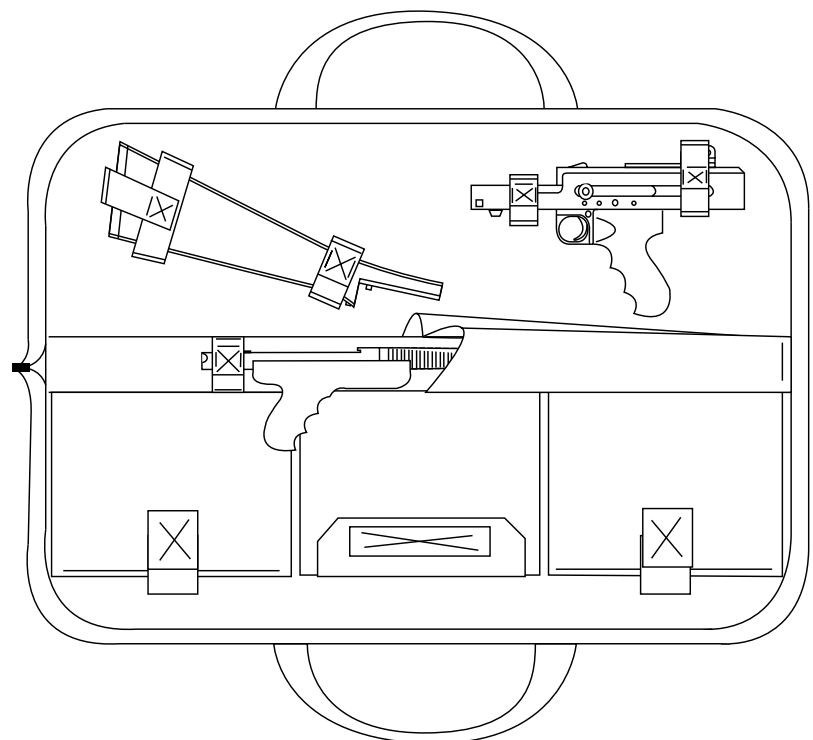





# **E & L MANUFACTURING INC.**

Home of the American 180 & The Best Brass Catchers In The World

180 WEB SITE: [www.american180.com](http://www.american180.com) E&L WEB SITE: [www.elmfg.com](http://www.elmfg.com)

E-Mail: [elmfg@frontiernet.net](mailto:elmfg@frontiernet.net)

Phone 541-874-2137 [www.brasscatchers.com](http://www.brasscatchers.com) Fax 541-874-3107

## **MAGAZINE BOTTOM PLATE (ALUMINUM)**

E & L Manufacturing now has available new Magazine Bottom Plates, made of aluminum and anodized to a hard black satin finish. The Magazine Bottom Plate Sets, contain all the necessary hardware required to be retrofitted to any of the Lexan Magazine Uppers.

BOTTOM PLATE AND HARDWARE — \$ 45.00

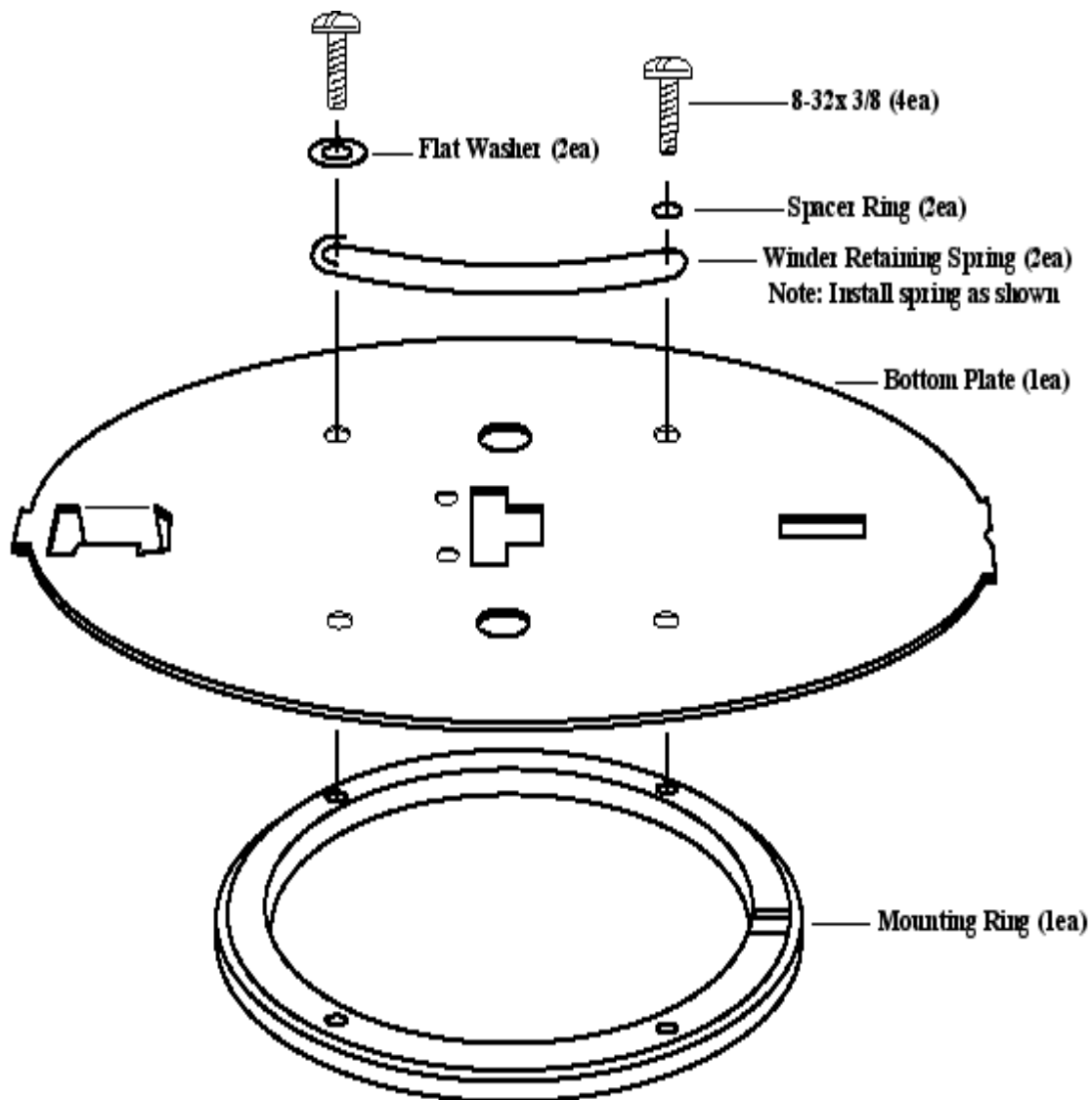



# **E & L MANUFACTURING INC.**

Home of the American 180 & The Best Brass Catchers In The World

180 WEB SITE: [www.american180.com](http://www.american180.com) E&L WEB SITE: [www.elmfg.com](http://www.elmfg.com)

E-Mail: [elmfg@frontiernet.net](mailto:elmfg@frontiernet.net)

Phone 541-874-2137 [www.brasscatchers.com](http://www.brasscatchers.com) Fax 541-874-3107

## **MAGAZINE LOADING TRAY & STAND**

The E&L Magazine Loading Stand holds the magazine with the loading tray attached at a specific angle; enabling you to load a standard three layer magazine in approximately three minutes, or a five layer magazine in about five minutes. Simply place the magazine (metal or plastic, with the E&L Loading Tray attached) on top of the loading stand as pictured below. Make sure to position the stand as indicated with the arrow pointing down and towards the operator.

